

Briquetting of Iron Bearing Materials

**A THESIS SUBMITTED IN PARTIAL
FULFILLMENT
OF THE REQUIREMENT FOR THE DEGREE
OF**

**Bachelor of Technology
in
Metallurgical and Materials Engineering**

By

**Biro Kishore Das (111MM0362)
Debaprasan Mallick (111MM0367)**

**Under the guidance of
Prof. SMARAJIT SARKAR**



**Department of Metallurgical and Materials Engineering
National Institute of Technology Rourkela
2015**

CERTIFICATE

This is to certify that the thesis entitled “**Briquetting of Iron Bearing Materials**” submitted by **Biro Kishore Das** (111MM0362) and **Debaprasan Mallick**(111mm0367) in partial fulfillment of the requirements for the award of **Bachelor of Technology** Degree in **Metallurgical and Materials Engineering** at **National Institute of Technology, Rourkela** is an original work carried out by them under my supervision and guidance.

The matter embodied in the thesis has not been submitted to any other University/ Institute for the award of any degree or diploma.

Prof. Smarajit Sarkar,
Dept. of Metallurgical &
Materials Engineering,
N.I.T Rourkela

ACKNOWLEDGEMENT

We express our sincere gratitude to the Department of Metallurgical and Materials Engineering, NIT Rourkela for giving us an opportunity to work on this project and allowing us access to valuable facilities in the department.

The students desire to articulate their earnest gratitude towards Prof. Smarajit Sarkar, Department of Metallurgical and Materials Engineering, NIT Rourkela for his pedantic guidance during the workings of the project. The scholars are greatly obliged to him for his insightful discourses on the concerned topic which made this project work exciting and revealing.

The scholars would also like to take this opportunity to express his deep gratitude towards Prof. S.C Mishra, Head of the Department, Metallurgical and Materials Engineering for motivating us when we need his experience and advices.

We would like to convey our heartfelt gratitude to Mr. Manoja Kumar Mohanty (PhD) to whom we are indebted for his relentless support and timely guidance during our project work.

Date: 6th May, 2015

Biro Kishore Das (111MM0362)

Debaprasan Mallick (111MM0367)

Department of Metallurgical and Materials Engineering,

National Institute of Technology, Rourkela

Rourkela-769008

ABSTRACT

This study deals with the recycling of the solid waste materials such as iron fines, mill scale, etc. for the efficient use in the blast furnace operations. The recycling of the materials causes improvement in the economic conditions of the industries and environmental conditions of the industrial region and also to make use of the mineral and energy resources. Recycling of these waste materials can be done by certain agglomerating process. In some cases briquetting is the best approach. Brex (briquettes) are prepared from stiff extrusion with iron bearing wastes. These brex has certain advantages over other agglomerates which makes them the efficient charge material for the blast furnace operation.

Contents

<u>index</u>	<u>Content</u>	Page no.
	CHAPTER 1: INTRODUCTION	7-13
<u>1.1</u>	Background theory	8
<u>1.2</u>	Agglomeration	9
<u>1.2.1</u>	Pelletization	9
<u>1.2.2</u>	Sintering	10
<u>1.2.3</u>	Briquetting	10
<u>1.3</u>	Hot Briquetted Iron	11
<u>1.4</u>	Stiff Extrusion process	12
<u>1.5</u>	Objectives	13
	CHAPTER 2:- LITERATURE REVIEW	14-17
	CHAPTER 3:- EXPERIMENTAL PROCEDURE	18-21
<u>3.1</u>	Materials used	19
<u>3.2</u>	Sample preparation	19
<u>3.3</u>	Tumbler Index and Abrasion Index	19
<u>3.4</u>	Reduction Test	20
<u>3.5</u>	Swelling index	21

	CHAPTER 4:- RESULTS AND DISCUSSIONS	22-28
<u>4.1</u>	Tumbler index and abrasion index	23
<u>4.2</u>	Degree of reduction at different temperature	23
<u>4.3</u>	Swelling index at different temperatures	24
<u>4.4</u>	XRD analysis of sample after reduction	26
<u>4.5</u>	Microscopic analysis	
<u>4.5.1</u>	Optical microscope	27
<u>4.5.2</u>	SEM analysis	28
	CHAPTER 5:- CONCLUSION	29-30
	FUTURE STUDY	31
	REFERENCES	32-33

CHAPTER 1:- INTRODUCTION

1.1 Background theory:-

India is the fifth largest steel producer in the world. The steel industries in India have grown in recent times by buying the other steel industries overseas. In India the demand for steel will grow reasonably for the construction of new airports and metro rail projects. But, there is massive set back due to the production of iron fines. Production of iron fines from blast furnace in iron making process causes decrease in the efficiency of the blast furnace.

The production of iron ore fines occurs at the early stages of processes in the integrated steel plant. This causes iron resource loses and also causes higher cost of utilization. Generation of iron waste from steel plant contain mainly blast furnace slag, blast furnace flue dust, sludge mill scale, etc. But these solid wastes contain various elements such as iron, carbon, calcium, zinc, lead, etc. These elements can be recovered and reused in an appropriate manner. As we can in this table the quantity and the chemical composition of the solid waste produced in 1 million ton integrated steel plant.

Waste	CaO	SiO ₂	MgO	Al ₂ O ₃	P	TiO ₂	Fe _T	K ₂ O	Na ₂ O	S	C	Million ton/1Million ton capacity
LD Slag	48.8	15	2.28	2.17	1.16	0.9	18.2	0.152	0.182	0.18	-	0.185
LD Sludge	10.9	1.83	0.82	0.89	0.11	0.06	59.04	0.26	0.152	-	-	0.011
Mill Scale	0.3	0.54	0.17	0.26	0.03	0.02	70.1	-	-	-	-	0.022
BF Sludge	5.35	8.12	0.98	0.67	-	-	51.7	-	-	-	3.77	0.009
Flue Dust	3.65	7.91	1.33	3.0	0.16	0.38	39.4	0.35	0.152	0.33	25.6	0.014
BFslag	32.3	33.1	8.68	19.34	-	1.12	0.36	0.77	0.11	1.1	-	0.376

1.2 Agglomeration:-

The fines that are produced in the mineral processing plants cannot be used directly in the blast furnace. These iron ore fines cannot be used directly in the blast furnace. They causes following threats:-

1. The fines decrease the bed permeability and hinder the bed reaction.
2. The fines leave the blast furnace with the flue gas, which brings down the blast furnace efficiency.

But the extraction of metal from these fines can be possible by forming in lumpy forms. These lumpy forms for can be handled easily and directly be used as charge for the blast furnace. These lumpy forms are called agglomerates and the process is called agglomeration. There are three main types of agglomeration process:- Pelletization, sintering and briquetting.

1.2.1 Pelletization:-

It is one of the agglomeration processes. A mixture of iron ore fines, binder and moisture is taken and it is placed and rolled inside a rotating inclined disc or a rotating horizontal drum. This produces green pellets which have enough strength to resist the firing stage. Pellets are fired inside a horizontal travelling grates and rotary kilns. The firing stages causes improvement of the crystal structure of the pellets and also bond formation takes place due to reaction between slag and iron oxide.

There are various advantages of Pelletization. They have open pores which gives good reducibility. The pellets are of small uniform size which minimize the segregation and improves the bed permeability. It has high strength so it can be easily been handled. The size of the pellet can be easily be maintained inside the blast furnace.

But these pellets have demerits. Inside the blast furnace, the strength reduces drastically and also swelling occurs. During firing, sticking occurs. It is difficult to make fluxed pellets. Their basicity is up to 1.2. At reducing conditions, there is break down of fluxed pellets.

1.2.2 Sintering:-

It is an agglomeration process which converts iron ore fines into large, hard and porous lumps. This is done by incipient fusion of the iron ore fines when it is heated near to the melting point which binds them together to form lump. The diffusion bonds which is formed during recrystallization and formation of hematite and magnetite crystals also binds them without melting. Sintering is done in Dwight-Lloyd machine. In this process, a mixture of iron bearing materials is placed on the permeable grate and the upper surface is heated and the air is sucked from the bottom. This not only causes formation of lumps but also removal of moisture and volatile impurities.

There are several advantages of sinters. It gives hard porous structure which gives good bed permeability. The volatile impurities and the moisture is removed. The softening temperature is increased.

The disadvantages of sinters are- it does not give a proper shape of the lump. Consumption of energy is high as high amount of heat is required to make sinter. Sintering is not fully done as the upper part is supplied with heat and has high temperature and the lower part has less temperature. It also causes environmental pollution. Fluxed sinter has less economical use than fluxed pellets.

1.2.3 Briquetting:-

The agglomeration process in which lumps are made by compacting the iron bearing fines and dust with addition of binder and also de-airing these mixtures inside the vacuum chamber of the briquetting machine.

So, briquetting process is developed to meet these demands. This process aims at recycle and reuse of the low grade iron ore and plant fines. This product can be used as a feed to blast furnace operation. This process has several benefits. It is mostly aims to saving of energy and decrease the environmental pollution. The demands for briquetting are increasing as they have uniform size, shape, weight and composition which complete the requirement for production process.

The mechanical properties of these briquettes are greatly affected by briquetting pressure, distribution of particle size and time of compressing. These parameters depend upon the composition of the briquettes.

To get briquettes of desired quality, we have to use binders. These binders hold the particles of the briquette together. There are various types of binders such as Portland cement, asphalt, pitch, sodium silicate, clay, plastics, sulphur liquor, lime, bentonite, tar, molasses, etc.

1.3 Hot Briquetted Iron:-

Direct reduction plants uses Hot Briquetted Iron and Direct Reduced Iron to make different materials. Earlier, direct reduction plants were established as a mini plant in which DRI were fed and consumed to the electric arc furnace. Nowadays, there is increase in the number of merchant direct reduction plants in various locations. In these plants, various alternate iron units are made and they are exported to the other steel industries. HBI get the importance due to its better shipping and handling characteristics.

In direct reduction process, oxygen is removed from iron ore to make sponge iron with high porosity. So due to its large specific surface area, DRI reacts with water or air very easily. This reaction produce large amount of heat as it is an exothermic reaction. The spongy structure of DRI does not allow the heat to escape. So, overheating and meltdown of DRI (which is stored in piles) occurs.

So due to this Hot Briquetting process has been developed. In this technique, the direct reduced iron is applied with high pressure immediately after it reduction at high temperatures. The high pressure causes densification of the direct reduced iron.

Hot briquetting of DRI has various advantages. It decreases the accessible surface, closure of internal pores, the apparent density increases and also reduces the reactivity of the DRI. Other advantages are there. The density is higher, improvement in handling, the shape and size is uniform, etc. These are the physical characteristics of HBI.

The DRI produced from fine ores are more reactive even it is cooled and it cannot be handled in the open easily. Due to this Hot briquetting is done which solves the problem of handling associated with fine particulate material.

Advantages of Hot Briquetted Iron over Direct Reduced Iron:-

- The loss of metallization is less in HBI even after longer time of storage.
- HBI can be stored at open air and it doesn't cause any problems.
- The chance for overheating minimizes during storage and transport.
- The fine that is produced during handling is less.
- High apparent density and Bulk density.
- Saturation of moisture is lowered.
- These are relatively small and has uniform product size which helps in easy charging in blast furnace.

Due to these advantages, most of the merchant reduction plants are going for planning and construction to make HBI.

1.4 Stiff Extrusion process:-

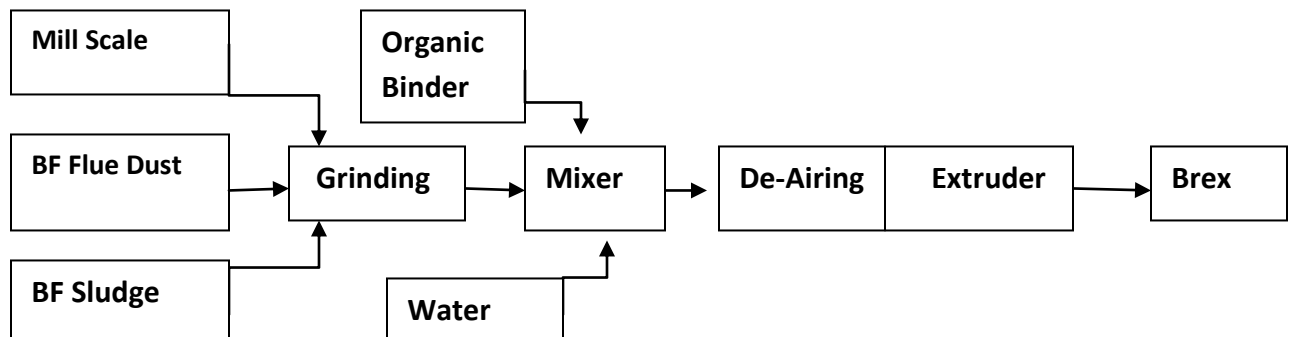

It is one of the most advanced and popular method of making briquettes. In this method, the solid waste from integrated steel plant such as blast furnace sludge, dust and iron ore fines are added by the auto loader creating stock piles of charge mix. This mixture is added with Portland cement and plasticizer in the mixers to homogenize it. The homogenized mixture is passed through the hopper of the briquetting line by the loader and fed to the extruder. On the application of pressure, the materials are compacted and the air inside the materials is removed.

At the end of the die, cylindrical briquettes (Brex) are obtained with high initial strength and having dense structure.

Advantages of Brex:-

- The stiff extrusion process of briquetting makes brex having high strength and reducibility. These briquettes are used in the blast in the blast furnace due to their good metallurgical properties.
- The brex can be made with high basicity and can be used in the small scale blast furnace which helps to reduce the rate of consumption of coke, dolomite and lime.
- This process of agglomeration has very fewer processing steps and fewer additives is required as compared to other agglomeration process.
- The method of making brex is very effective in economical ways. This reduces the cost of the solid metal waste and metal reclamation.

1.5 Objectives:-

- To study the mechanical properties such as tumbler index and abrasion index of the brex that is obtained after stiff extrusion.
- To study the reducing behavior and swelling behavior of the brex at different reducing temperatures.
- To study the microstructure of the brex reduced at different temperatures by optical microscopic analysis and SEM analysis.
- To determine the phases present at the brex (reduced at different temperatures) by XRD analysis.

CHAPTER 2:- LITERATURE REVIEW

- F. Kurunovet, et al. found out that the briquettes retain their strength upto reduction temperature of 700⁰C-750⁰C. It is due to the cement stone. On future reduction at high temperature, strength is retained due to the formation of metallic iron on the briquette's surface. The iron oxide on the briquette surface is reduced to metallic iron. [9]
- F. Kurunovet , et al. found that on briquetting of iron bearing metallurgical wastes consume less fuel, during smelting operation inside the blast furnace, as compared to other technologies. This shows that briquetting has clear advantage from an economic and environmental point of view. Smelting of briquettes causes less emission of green house gases. [7]
- Cypres, et al. found out that during the pyrolysis of coal and iron oxide blend, the reduction of hematite occurs at 400⁰C to 500⁰C but cannot be measured due to the primary volatization of the coal. The hematite is reduced to magnetite and eventually to wustite to metallic iron. The reduction proceeds faster by using hematite and it starts earlier due slow rate of heating and low rank of coal. The reduction completes around 1200⁰C and above. The reducing gases are CO and H₂ as after the reduction they form CO₂ and H₂O. At high temperatures, reduction by CO takes place with consumption of coke. [19]
- Yang, et al. found that the reduction of Fe₂O₃ is feasible by employing solid fuel (lignite) with steam into the fixed bed reactor. This causes the reduction very feasible as pure carbon dioxide is evolved as off-gases. The Fe₂O₃ is converted to Fe₃O₄. The rate of reaction of char gasification is slow as compared with the iron oxide reaction with char gasified intermediates. So, in the reduction process, the char gasification as the rate-limiting step. [17]
- Godinski, et al. discussed about the advantages of carbon as reducing agents in briquettes over other reducing agents. Use of carbon produces gaseous carbon monoxide but if we use other reducing agents then the oxides will enter in to the slag phase. The oxidation of carbon in the briquette generates heat which increases the heating capacity of the furnace. This causes improvement in the performance indices if the heat is utilized properly. [18]

- Richard B. Steele, et al. found that the mechanical strength of the briquette is high enough at the extruder's die's exit and it can be easily handled. After curing, the strength of brex is high enough for storage, transportation and in the charge bed of metallurgical furnace. These brex can be subsequently used in blast furnace, EAF and other DRI processes. [6]
- Y. Dalmia, et al. found that the brex produced from stiff extrusion process of briquetting have high strength and high reducibility. These brex are used in the blast furnace for their efficient metallurgical properties. Due to these metallurgical properties, the lime and dolomite has been rejected entirely and the coke rate has been reduced by 150kg/tn of hot metal. [3]
- A. M. Bizhanov, et al. found that the fine fraction of brex has been migrated to their surface during extrusion can be explained by hydrodynamic approach. This migration causes strengthening effect of the surface layer of the brex. This model is explained by using two different size particles. The effect of surface friction, particle-size and particle size distribution is also taken into consideration to explain this hydrodynamic approach model. [5]
- N. A. El-Hussiny, et al. found that with increasing in mill scale ratio in the mixture gives better mechanical properties of the briquettes. The increase in coke breeze content in the briquette mixture gives better reducibility in the briquettes. The XRD pattern of the briquettes also revealed that on increasing the reduction temperature, there is increase in the alpha iron and gamma iron phase. On microscopic analysis, it is also seen that the increase in the coke breeze content up to 11% , there is increase in the quantity of metallic iron. [8]
- S. Belkin, et al. found that the iron-coke briquettes which are made with cement binder and metal chips have high heat resistance and disintegration does not occurs when it is heated at high temperatures under reduction condition under high load inside blast furnaces. The quality of briquettes is very high for blast furnace smelting as it comprises of metallic iron, reducing agents and fluxing agents. Briquettes which are made by using cement binder recycle the coke fines and finely metallic fines for factories where sinter plant is not installed. [4]

- Ramiro Conceic NASCIMENTMO, et al. found that metallic iron is formed when the iron agglomerate is reduced at high temperature. At first, the briquette is reduced to magnetite. This is due to the formation of magnetite. It also explains the morphologies during the reduction. During the first stage of reduction, the magnetite is reduced to wustite and thus the volatile matter and the water of crystallization in the cement binder evaporates which causes swelling. In second stage of reduction, the wustite is reduced to iron which makes the agglomerate dense and the water vapor and volatile matter has no role in it. The reduction is due to carbon monoxide. [2]
- M. J. Blesa, et al. found that the mechanical strength of the smokeless fuel briquettes increases with increase in curing time. On further analysis by infrared spectroscopy, it is seen that the briquettes with more curing time has more stretching vibration associated with the aliphatic carbon-hydrogen bonds. On increasing the curing time at room temperature the evolution of methyl group takes place. The methyl group mainly comes from the binder. [15]

CHAPTER 3:- EXPERIMENTAL PROCEDURE

3.1 Materials used:-

The materials used in making briquettes:-

Table 1:-mixing percentage of solid waste

LD Sludge	40%
BF Dust	20%
Iron Ore Dust	10%
Mill Scale	20%
Coke Fine	5%
Binder	3.5%
Plasticizer	1.5%

3.2 Sample preparation:-

The whole mixture is mixed well without adding Portland cement. Then this mixture is homogenized by adding Portland cement. It is then passed into a vacuum chamber. The vacuum chamber contains a pressure of 0.5×10^{-3} Bar. This mixture is then extruded by the die with a pressure of 100 kg/m^3 .

3.3 Tumbler Index and Abrasion Index:-

Tumbler index is the measure of the resistance of the material to breakage or degradation by impact. It is carried out in a tumbler rotating drum. The samples are placed inside the drum and the door fitted tightly. The drum is then rotated for a total of 200 revolutions at 25 rotations per minute. All the materials are removed from the drum gently by slowly opening the door. These materials are then sieved on a 6.3mm sieve and a 0.5mm sieve.

Tumbler index, $T = (m_1/m) \times 100$

m =mass of the sample before test

m_1 =mass of the sample retained in 6.3mm sieve after test

Abrasion index is the relative measure of the material's degradation due to abrasion. It is measured during the measurement of tumbler index.

Abrasion index, $A = \frac{(m - (m_1 + m_2))}{m} \times 100$

m_2 = mass of the sample which passes through 6.3mm sieve but retained at 0.5mm sieve.

3.4 Reduction Test:-

The test is carried out inside the muffle furnace. The furnace is heated up to the required temperature. Then the single pre-weighted sample is placed centrally inside closely packed pet coke in graphite crucible. It is then heated at required temperature and soaked for 1 hour. After soaking, the crucible is taken out, cooled in open atmosphere and final weight is taken. 5 samples are taken and all of them are fired with different temperatures (i.e. 1000⁰C, 1100⁰C, 1200⁰C, 1300⁰C and 1400⁰C).

The iron content of the iron ore fines is 55.7%.

So oxygen content = $(48/112) \times 55.7\%$

$$= 23.87\%$$

The oxygen content in the Brex before reduction can be calculated using this value.

Therefore, the reduction is calculated as:-

$$\% \text{Reduction} = \frac{\text{loss in weight}}{\text{initial weight of oxygen}} \times 100$$

From the reduction test, percentage of metallization can also be calculated:-

$$\% \text{metallization} = \frac{Fe_{\text{metal}}}{Fe_{\text{total}}} \times 100$$

3.5 Swelling index:-

It is the measure of swelling behavior of the briquettes during reduction. High swelling index causes creation of cracks and voids which further cause fragmentation of briquettes and hence it cannot be used in the blast furnace operation.

Initially, diameter and length of the brea sample is taken by using Vernier Calipers before firing and volume is calculated. Then after firing at different temperatures (such as 1000⁰C, 1100⁰C, 1200⁰C, 1300⁰C and 1400⁰C), again the diameter of the sample are calculated.

The swelling index is calculated as percentage increase in volume.

$\% \text{increase in diameter} = (\text{increase in volume} / \text{original volume}) \times 100$

CHAPTER 4:- RESULTS AND DISCUSSION

4.1 Tumbler index and abrasion index:-

The tumbler index found to be 96.21. It means that the brex has high strength and resistance towards breakage when it is allowed to fall from the top of the blast furnace to the bottom of it. The abrasion index of the brex is found out to be 3.63. Low abrasion index means it has better mechanical properties. The degradation of particles is less due to abrasion.

4.2 Degree of reduction at different temperature:-

Table 1:- Degree of reduction and degree of metallization

Temperature ($^{\circ}\text{C}$)	Deg. of reduction (%)	Fe _{Metal}	Fe _{Total}	Deg. of metallization (%)
1000	27.08	2.89	60.52	4.77
1100	57.97	35.37	67.92	52.07
1200	84.39	47.87	72.26	66.24
1300	88.42	68.36	75.87	90.01
1400	91.18	77.37	79.18	97.71

As we increase the fired temperature, the degree of reduction increases. The oxygen content becomes lower and the iron content also increases. The loss of oxygen content causes decrease in the mass of the briquette. The degree of metallization also increases with increase in reduction temperature. It is due to the conversion of wustite to metallic iron at high temperatures.

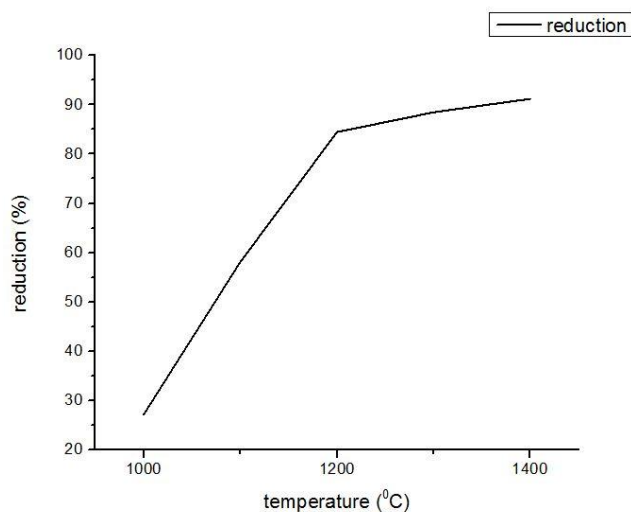

Figure 1:- Graphical representation of degree of reduction with reduction temperature.

4.3 Swelling index at different temperatures:-

Table 2:- swelling index with increasing reduction temperature

Temperature (°C)	Swelling index
1000	20
1100	15
1200	13
1300	9
1400	5

There is decrease in the change in volume of the Brex as the firing temperature increases. So there is decrease in the swelling index of Brex. The factors responsible for swelling of briquettes are:

1. The reduction of hematite to magnetite causes swelling at high temperature which leads to crack formation on briquette. On further increase in temperature causes reduction of magnetite to wustite causes shrinkage of the sample and later metallic iron is formed. This causes little swelling as compared to magnetite formation.
2. Swelling of briquettes occurs due to increase in slag forming oxides like CaO, Al₂O₃, SiO₂ and MgO.
3. With increase in particle size the swelling also increases due to the formation large cracks.
4. Swelling can be reduced by addition of hydrogen gas in reducing gas.

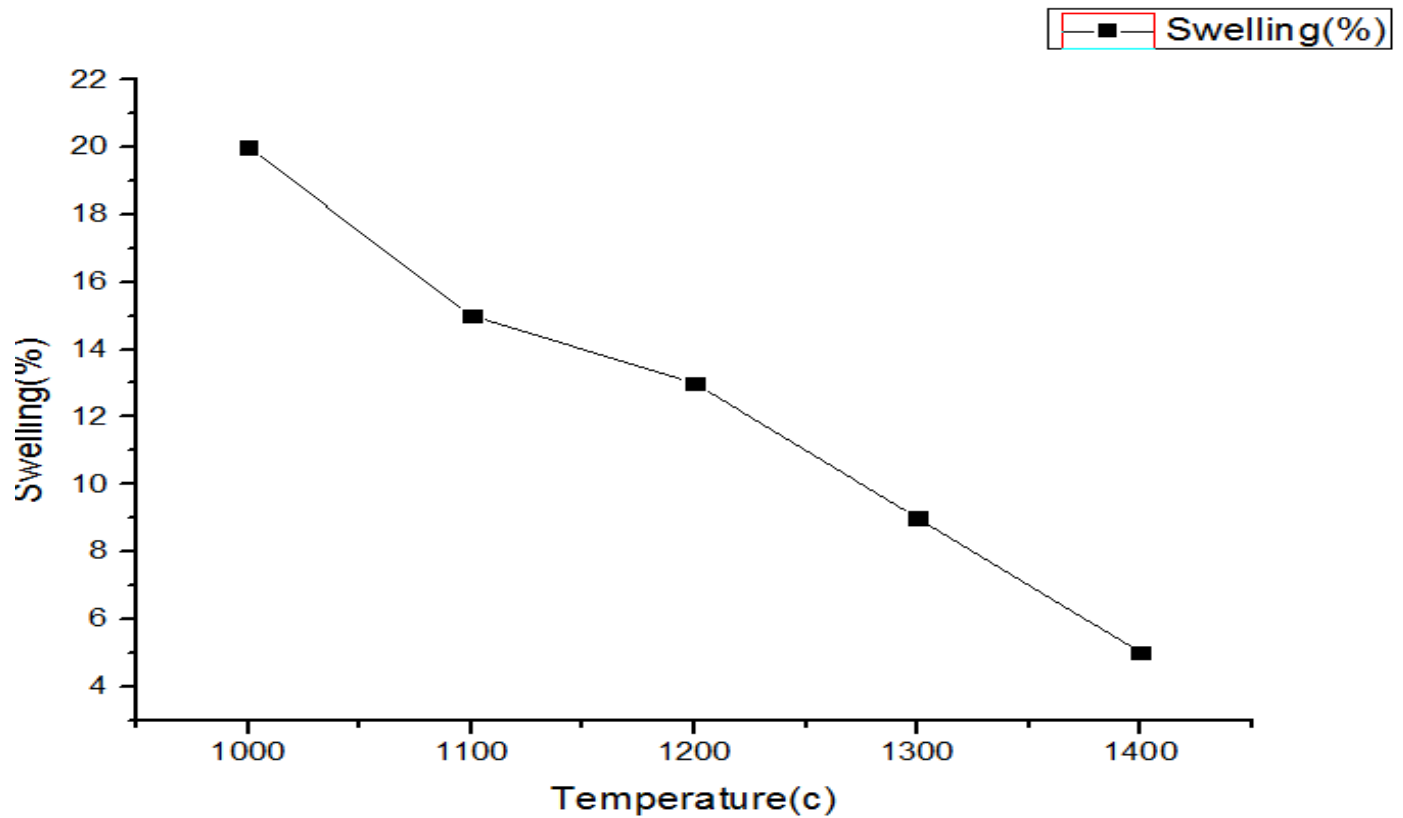

Figure 2:- Graphical representation of swelling index with reduction temperature

As we can see in this graph, the swelling index decreases with increase in temperature. The change in volume of bauxite also decreases with temperature.

When the briquettes are reduced at high temperature, the hematite ore converted to magnetite and the volume increases drastically which develop cracks and disintegrate to smaller detached grains. On further reduction, the magnetite is transformed to wustite grains which is further smaller and has fragmented grains. On further reduction, metallic iron is formed which is in small round spheres and dispersed as patches. Reduced iron is formed at the pool of liquid slag. So due to the surface tension of the slag, the metallic iron moves away from wustite and takes a spheroid shape.

4.4 XRD analysis of sample after reduction:-

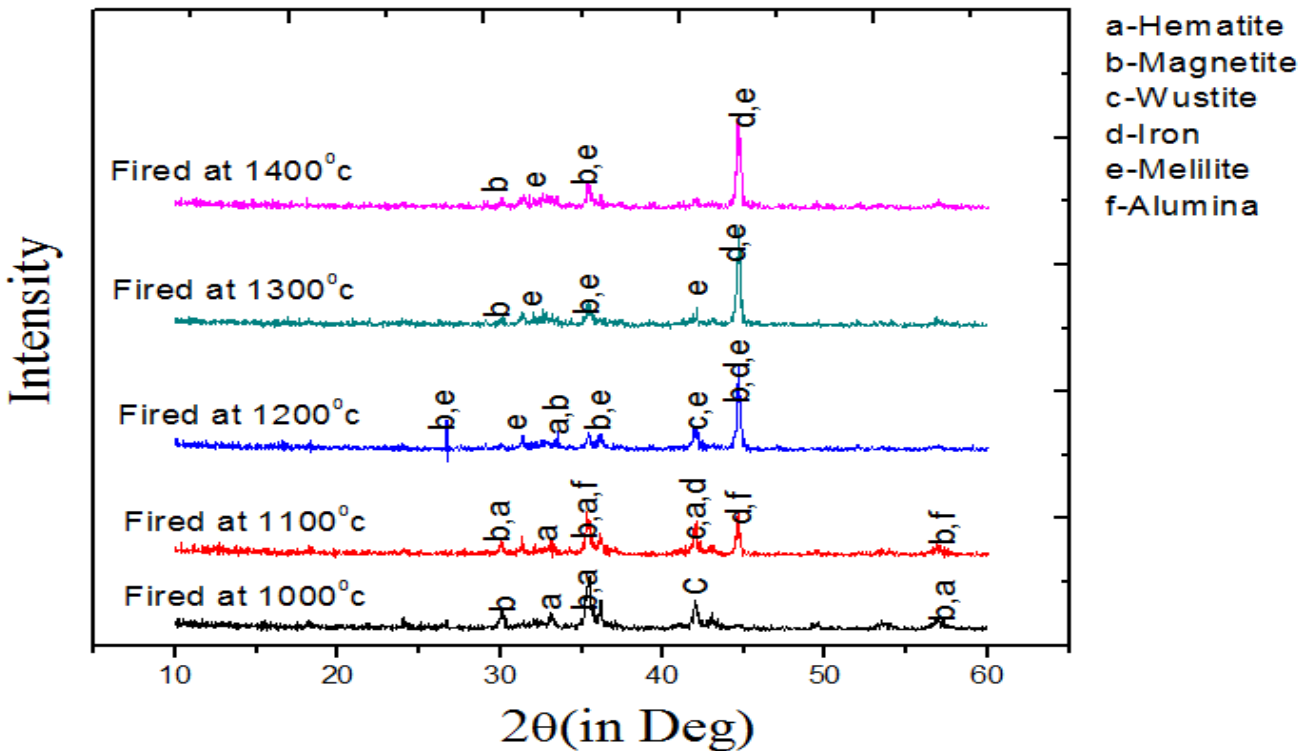

Figure 3:- This graph showing the XRD image of samples which has been fired at 1000°C, 1100°C, 1200°C, 1300°C and 1400°C.

The briquette which is reduced at 1000 degree centigrade for 1 hour has high intensities of the peak characteristics of wustite and magnetite. The 1400°C reduced sample which is soaked for 1 hour has high intensity peak characteristics of metallic iron and melilite and a much decreased amount of intensities peaks of magnetite.

When the briquettes are reduced at high temperature, the disintegrated particles reduced to wustite. Then, a molten slag layer (melilite) covers the wustite. Iron carbide is formed when carbon monoxide reacts with the wustite. Pressure is generated by the carbon monoxide inside the fragmented particles which pushes out the iron particles and thus the metallic iron content increases at high reduction temperature. The slag layer provides enough lubrication for the iron particles to move out.

4.5 Microscopic analysis:-

4.5.1 Optical microscopy:-

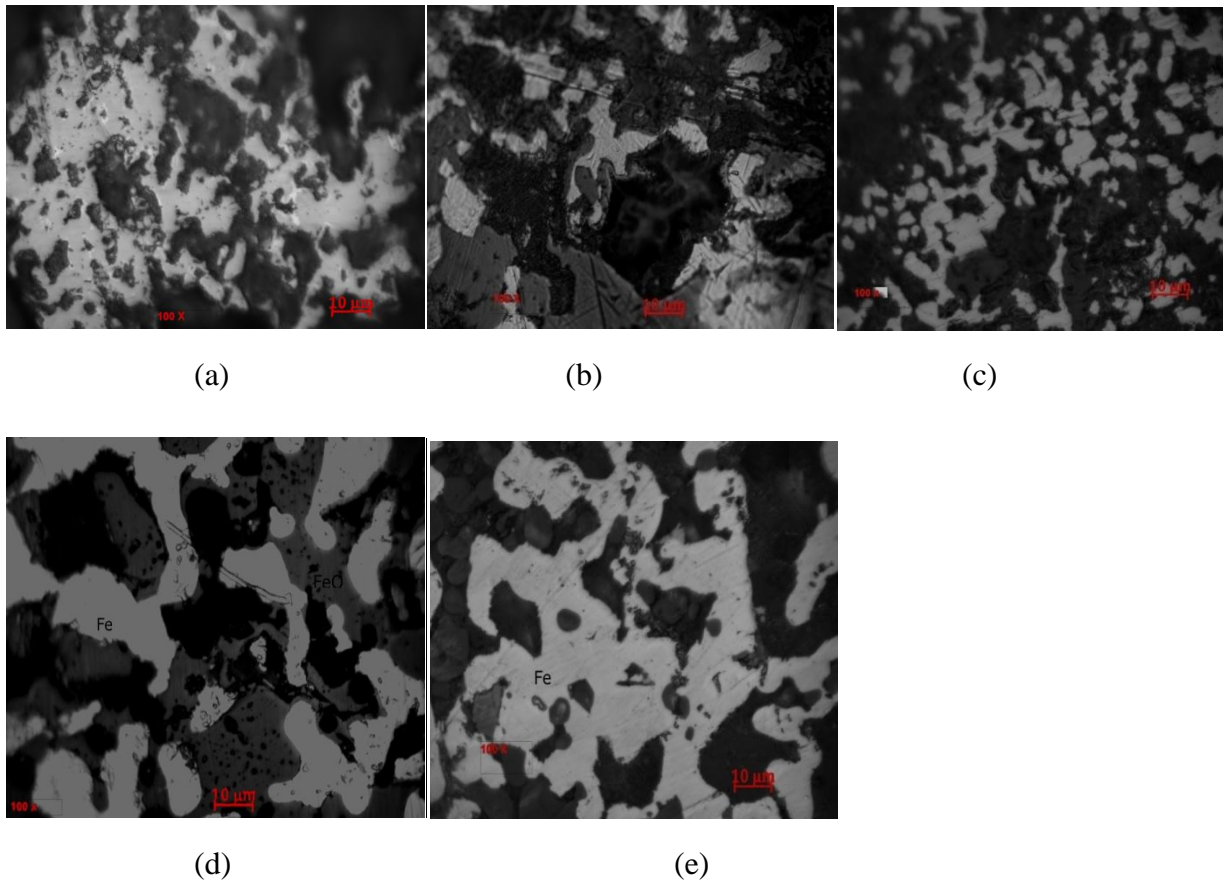

Figures from (a) to (e) show the microscopic analysis of brex at different reduction temperature 1000°C , 1100°C , 1200°C , 1300°C and 1400°C respectively.

At 1000°C less amount of metallic iron is formed and maximum amount is formed at 1400°C . In fig. a, the gray-white color is hematite (Fe_2O_3) and gray color is FeO. In Fig. d and fig. e, grey color is FeO, deep black color are pores and the bright colored one is metallic iron.

There is also slag in fig. e which is gray in color but it contain in very less amount.

4.5.2 SEM analysis:

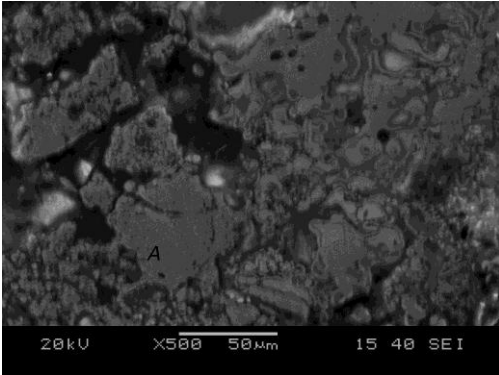

Fig. 3 (Brex reduced at 1300°C)

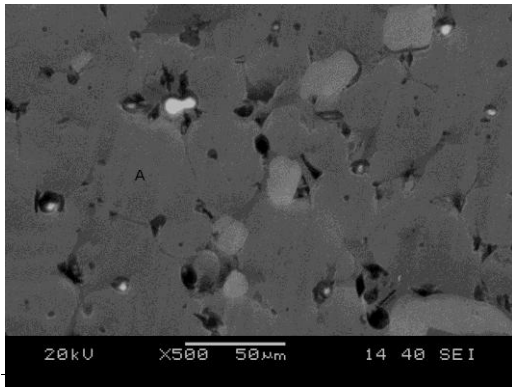

Fig 4 (Brex reduced at 1400°C)

In 1300°C reduced brex, iron grains are precipitate in dendritic form. In 1400°C reduced brex, iron particles are formed in small spheres and appeared to be dispersed patches. The metallic iron takes spheroid shape at high reduction temperature. This causes increase in the metallization percentage in the briquette.

CHAPTER 5:- CONCLUSIONS

From the following experiments on the brex, we have concluded that:

- The briquettes have tumbler index of 96.21. This causes the resistance of briquettes to impact when it is charged from the top of the blast furnace.
- The brex are heated up to 1400⁰C under reducing conditions and they do not disintegrate at this temperature.
- The degree of reduction increases with reduction temperature as there is an increase in the loss of mass of the briquette in the reducing condition. This indicates that briquettes have good reduction potential.
- The swelling behavior of the briquette decreases with increase in the reduction temperature above 1000⁰C. This makes the briquettes as efficient charge materials in the blast furnace operation.
- The micro-structural study of the briquettes at different reduction temperatures reveals that with increase in the reduction temperature the metallic iron grains are formed and later metallic iron takes round shape.

From this study it is revealed that the briquettes can be made from waste materials of the integrated iron plant and it also has good potential as a charging material in the blast furnace operation.

Future study:-

- Study of reduction behavior of brex with different composition of flue dust and mill scale with and without coke fine.
- Study the effect of pressing load and addition of binder on the mechanical strength of brex.
- Study of reduction behavior of brex on varying the time and temperature of the reduction process.
- Study the effect of cold crushing strength with varying curing time and curing temperature.

Reference:-

1. Senk Deiter, Wang Shaowen, De Melo Martins Karla and Stephany Christoph: “Research in the reduction of iron ore agglomerates including coal and carbon-containing dust”; ISIJ International; volume no. 45(2005), pp. 607
2. Ramiro Conceic NASCIMENTMO, Marcelo Breda MOURA and Jos Deodoro Trani CAPPOCCHI: “Microstructures of Self-reducing Pellets Bearing Iron Ore and Carbon”; ISIJ International, Vol. 37 (1 997),pp. 1055
3. Dalmia Yogeh, Kurunov Ivan Steele, Richard and Bizhanov Aitber; “New charge materials for blast furnace”; Technical Contribution to the 6th International Congress on the Science and Technology of Iron Making –ICSTI, 2012
4. Belkin A. S, Yusfin Yu, Kurunov I. F., Travyon A. Ya., Tikhonov D. N., Travyanov A. Yeah, Svtiko S. V., Borodin Yu. V., Feschenko S. A and pleshlov V. I.,; “Use of iron-coke brequettes on a cement binder in the blast furnace smelting”; Metallurgist; Vol.47, Nos 3-4,2003
5. Bizhanov A. M., Kurunov I. K. Andlovnin D. V.; “Mechanism of migration of the fine fraction in the production of the extrusion briquettes (brex)”; Metallurgist
6. Richard B. S., Bizhanov A. M.,; “Metallurgical properties of brex(extruded briquettes)”; J. C. steele & Sons, Inc, www.jcsteel.com
7. Kurunov I. F., Titov V, N., Bol`Shakova O. G.; “Analysis of the efficiency of alternative methods for recycling of iron bearing materials wastes”; Metallurgist Vol. 50; 2006
8. El-Hussiny N.A., Shalabi M.E.H; “ A self-reduced intermediate product from iron and steel plant waste materials using a briquettes process”; powder technology, Vol. 205,2011
9. Kurunov I. F., Malysheva T. Y., and Bol`shakova O.G.; “A study of the phase composed of iron-ore briquettes to asses their behavior ina a blast furnace”; metallurgist, Vol. 51, Nos. 10-11, 2007.
10. Taylor JW, Hennah L. The effect of binder displacements during briquetting on the strength of formed coke. Fuel 1991;70:873–6.

11. Paul SA, Hull AS, Plancher H, Agarwal PK. Use of asphalts for form coke briquettes. *Fuel Process Technol* 2002;76:211–30.
12. Sharma AK, Bas BP, Tripathi PSM. Influence of properties of bituminous binders on the strength of formed coke. *Fuel Process Technol* 2002;75:201–14.
13. Blesa MJ, Fierr V, Miranda JL, Moliner R, Palacios JM. Effect of the pyrolysis process on the physicochemical and mechanical properties of smokeless fuel briquettes. *Fuel Process Technol* 2001;74:1–17.
14. Blesa MJ, Miranda JL, Izquierdo MT, Moliner R. Curing temperature effect on mechanical strength of smokeless fuel briquettes prepared with molasses. *Fuel* 2003;82:943–7.
15. Blesa MJ, Miranda JL, Izquierdo MT, Moliner R. Curing time effect on mechanical strength of smokeless fuel briquettes. *Fuel Process Technol* 2003;80:155–67.
16. Blesa MJ, Miranda JL, Moliner R, Izquierdo MT, Palacios JM. Low-temperature co-pyrolysis of a low-rank coal and biomass to prepare smokeless fuel briquettes. *J Anal Appl Pyrol* 2003;70:665–77.
17. Jing-Biao Yang, Ning-Sheng Cai, Zhen-Shan Li, “Reduction of iron oxide as an oxygen carrier by coal pyrolysis and steam char gasification intermediate products, *Energy & fuels* “ Vol (6), (2007) ,3360–3368.
18. N.A. Godinskii, N.N. Kushnarev, D.S. Yakhshuk, V.I. Kotenev, E.Yu. Barsukova, “Use of iron carbon-bearing briquettes in electric steelmaking”, Translated from *Metallurgist* 47 (1) (January 2003) 43–45.
19. René Cyprès, Claire Soudan-Moinet, Pyrolysis of coal and iron oxides mixtures. 2. Reduction of iron oxides, *Fuel* 60 (1) (1981), pp: 33–39.